

Lecture 13: Pretraining + Transformers

Alan Ritter

(many slides from Greg Durrett)

Pretraining / ELMo

Recall: Context-dependent Embeddings

- ▶ How to handle different word senses? One vector for *balls*

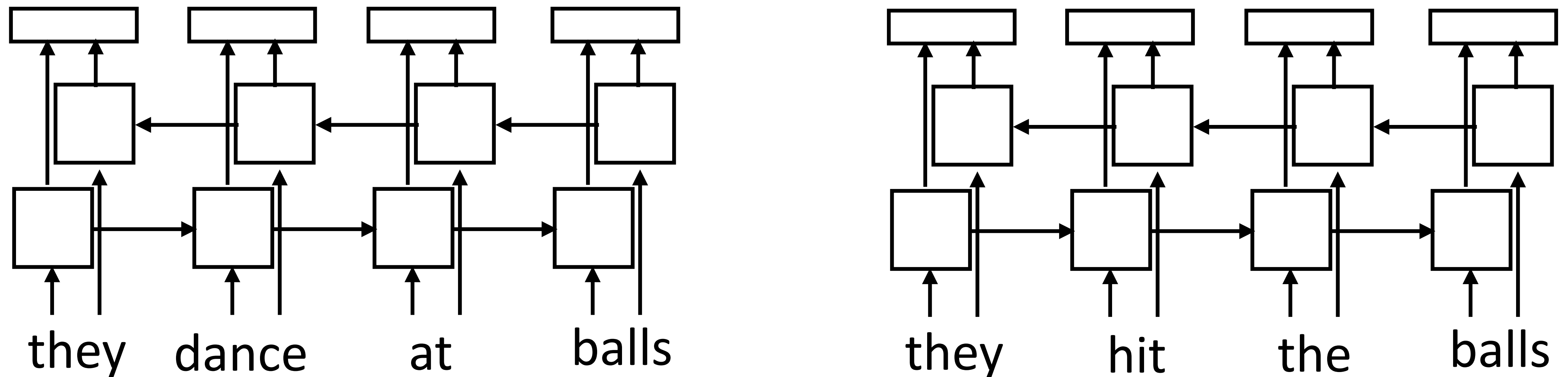

- ▶ Train a neural language model to predict the next word given previous words in the sentence, use its internal representations as word vectors

ELMo

- ▶ Key idea: language models can allow us to form useful word representations in the same way word2vec did
- ▶ Take a powerful language model, train it on large amounts of data, then use those representations in downstream tasks
- ▶ What do we want our LM to look like?

How to apply ELMo?

- ▶ Take those embeddings and feed them into whatever architecture you want to use for your task
- ▶ *Frozen* embeddings: update the weights of your network but keep ELMo's parameters frozen
- ▶ *Fine-tuning*: backpropagate all the way into ELMo when training your model

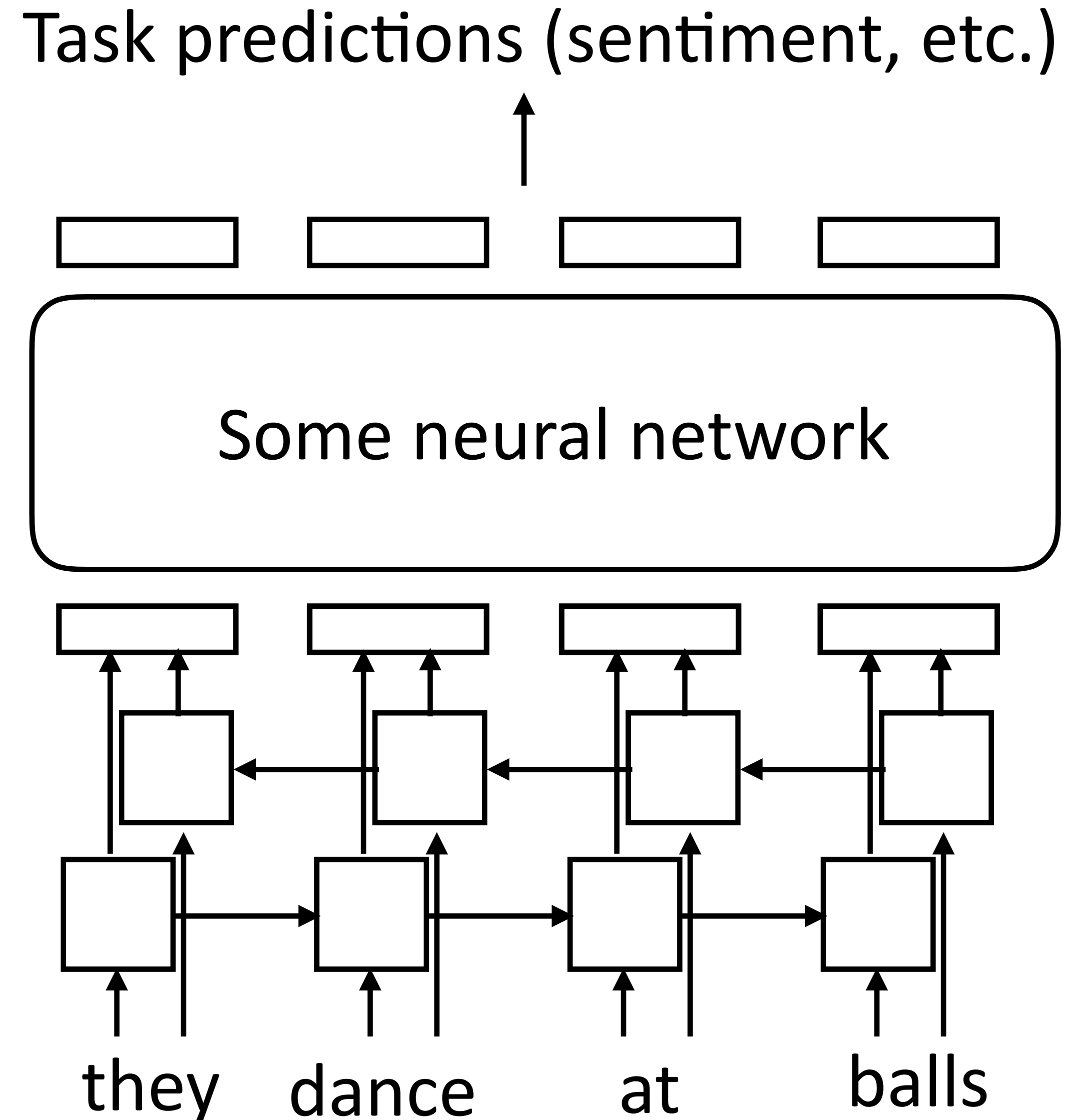

Results: Frozen ELMo

TASK	PREVIOUS SOTA		OUR BASELINE	ELMo + BASELINE	INCREASE (ABSOLUTE/ RELATIVE)
SQuAD	Liu et al. (2017)	84.4	81.1	85.8	4.7 / 24.9%
SNLI	Chen et al. (2017)	88.6	88.0	88.7 ± 0.17	0.7 / 5.8%
SRL	He et al. (2017)	81.7	81.4	84.6	3.2 / 17.2%
Coref	Lee et al. (2017)	67.2	67.2	70.4	3.2 / 9.8%
NER	Peters et al. (2017)	91.93 ± 0.19	90.15	92.22 ± 0.10	2.06 / 21%
SST-5	McCann et al. (2017)	53.7	51.4	54.7 ± 0.5	3.3 / 6.8%

- ▶ Massive improvements across 5 benchmark datasets: question answering, natural language inference, semantic role labeling (discussed later in the course), coreference resolution, named entity recognition, and sentiment analysis

How to apply ELMo?

Pretraining	Adaptation	NER	SA	Nat. lang. inference	Semantic textual similarity			
		CoNLL 2003	SST-2	MNLI	SICK-E	SICK-R	MRPC	STS-B
Skip-thoughts	❄️	-	81.8	62.9	-	86.6	75.8	71.8
ELMo	❄️	91.7	91.8	79.6	86.3	86.1	76.0	75.9
	🔥	91.9	91.2	76.4	83.3	83.3	74.7	75.5
	Δ=🔥-❄️	0.2	-0.6	-3.2	-3.3	-2.8	-1.3	-0.4

► How does frozen (❄️) vs. fine-tuned (🔥) compare?

► Recommendations:

Conditions			Guidelines
Pretrain	Adapt.	Task	
Any	❄️	Any	Add many task parameters
Any	🔥	Any	Add minimal task parameters ⚠️ Hyper-parameters
Any	Any	Seq. / clas.	❄️ and 🔥 have similar performance
ELMo	Any	Sent. pair	use ❄️
BERT	Any	Sent. pair	use 🔥

Why is language modeling a good objective?

- ▶ “Impossible” problem but bigger models seem to do better and better at distributional modeling (no upper limit yet)
- ▶ Successfully predicting next words requires modeling lots of different effects in text

Context: My wife refused to allow me to come to Hong Kong when the plague was at its height and –” “Your wife, Johanne? You are married at last ?” Johanne grinned. “Well, when a man gets to my age, he starts to need a few home comforts.

Target sentence: After my dear mother passed away ten years ago now, I became -----.

Target word: lonely

- ▶ LAMBADA dataset (Papernot et al., 2016): explicitly targets world knowledge and very challenging LM examples
- ▶ Coreference, Winograd schema, and much more

Why is language modeling a good objective?

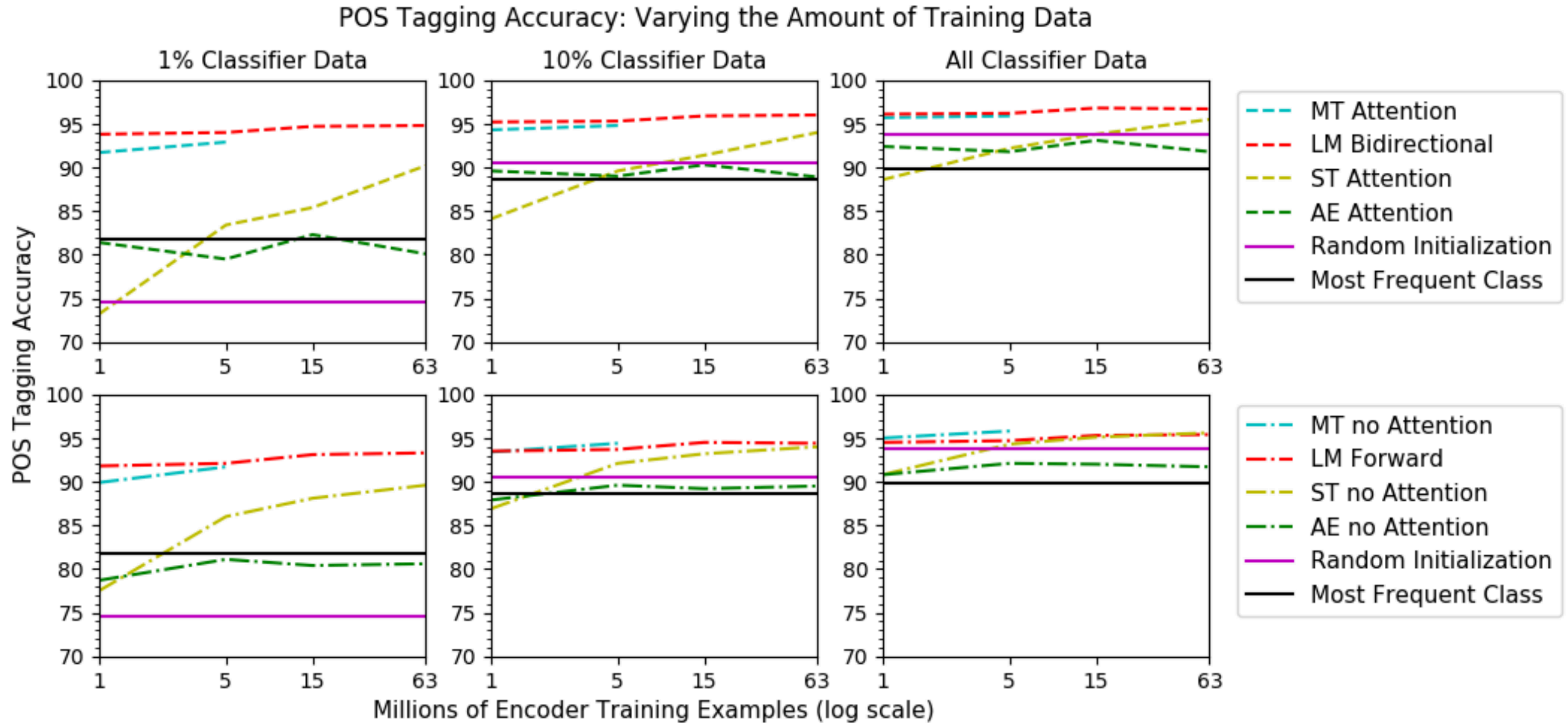

Why did this take time to catch on?

- ▶ Earlier version of ELMo by the same authors in 2017, but it was only evaluated on tagging tasks, gains were 1% or less
- ▶ Required: training on lots of data, having the right architecture, significant hyperparameter tuning

Probing ELMo

- ▶ From each layer of the ELMo model, attempt to predict something: POS tags, word senses, etc.
- ▶ Higher accuracy => ELMo is capturing that thing more nicely

Model	F ₁
WordNet 1st Sense Baseline	65.9
Raganato et al. (2017a)	69.9
Iacobacci et al. (2016)	70.1
CoVe, First Layer	59.4
CoVe, Second Layer	64.7
biLM, First layer	67.4
biLM, Second layer	69.0

Table 5: All-words fine grained WSD F₁. For CoVe and the biLM, we report scores for both the first and second layer biLSTMs.

Model	Acc.
Collobert et al. (2011)	97.3
Ma and Hovy (2016)	97.6
Ling et al. (2015)	97.8
CoVe, First Layer	93.3
CoVe, Second Layer	92.8
biLM, First Layer	97.3
biLM, Second Layer	96.8

Table 6: Test set POS tagging accuracies for PTB. For CoVe and the biLM, we report scores for both the first and second layer biLSTMs.

BERT

Recall: Self-Attention

- ▶ Each word forms a “query” which then computes attention over each word

$$\alpha_{i,j} = \text{softmax}(x_i^\top x_j) \quad \text{scalar}$$

$$x'_i = \sum_{j=1}^n \alpha_{i,j} x_j \quad \text{vector} = \text{sum of scalar} * \text{vector}$$

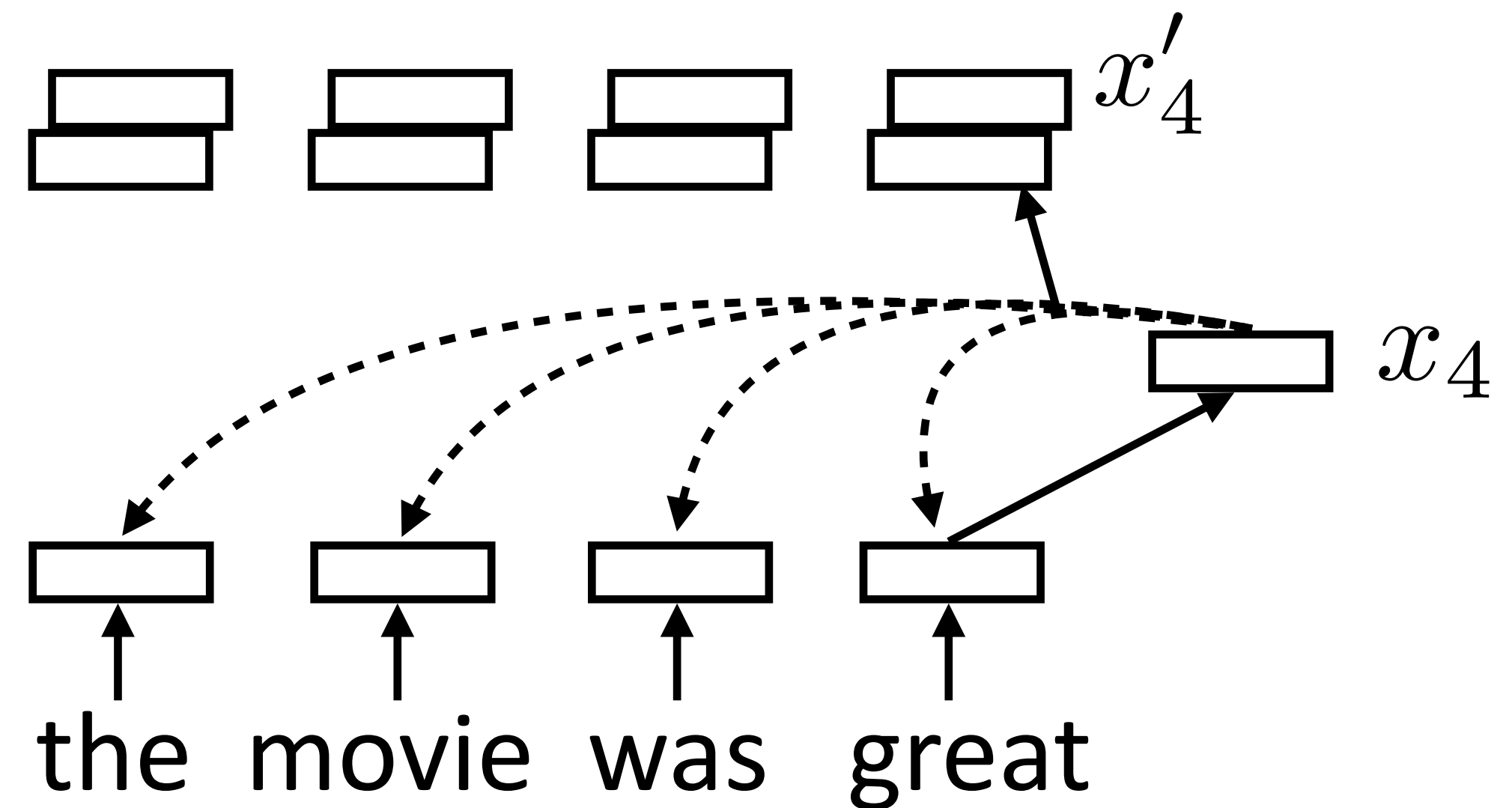

- ▶ Multiple “heads” analogous to different convolutional filters. Use parameters W_k and V_k to get different attention values + transform vectors

$$\alpha_{k,i,j} = \text{softmax}(x_i^\top W_k x_j) \quad x'_{k,i} = \sum_{j=1}^n \alpha_{k,i,j} V_k x_j$$

Recall: Multi-Head Self Attention

$$X \times W^Q = Q$$

$$X \times W^K = K$$

$$X \times W^V = V$$

Alammar, *The Illustrated Transformer*

sent len x sent len (attn for each word to each other)

$$\text{softmax} \left(\frac{Q \times K^T}{\sqrt{d_k}} \right) \times V$$

$$= Z$$

sent len x hidden dim

Z is a weighted combination of V rows

Recall: Transformers

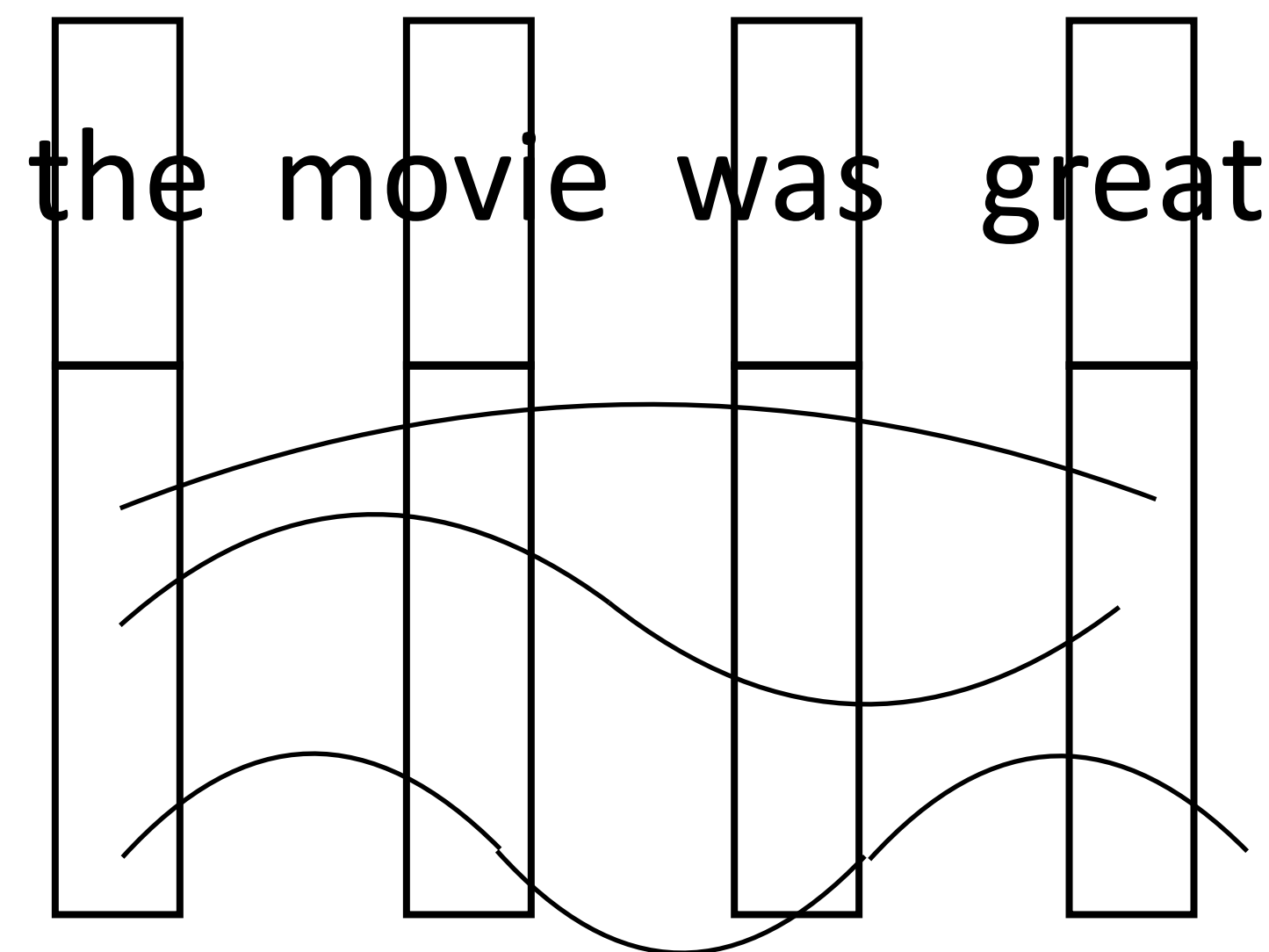
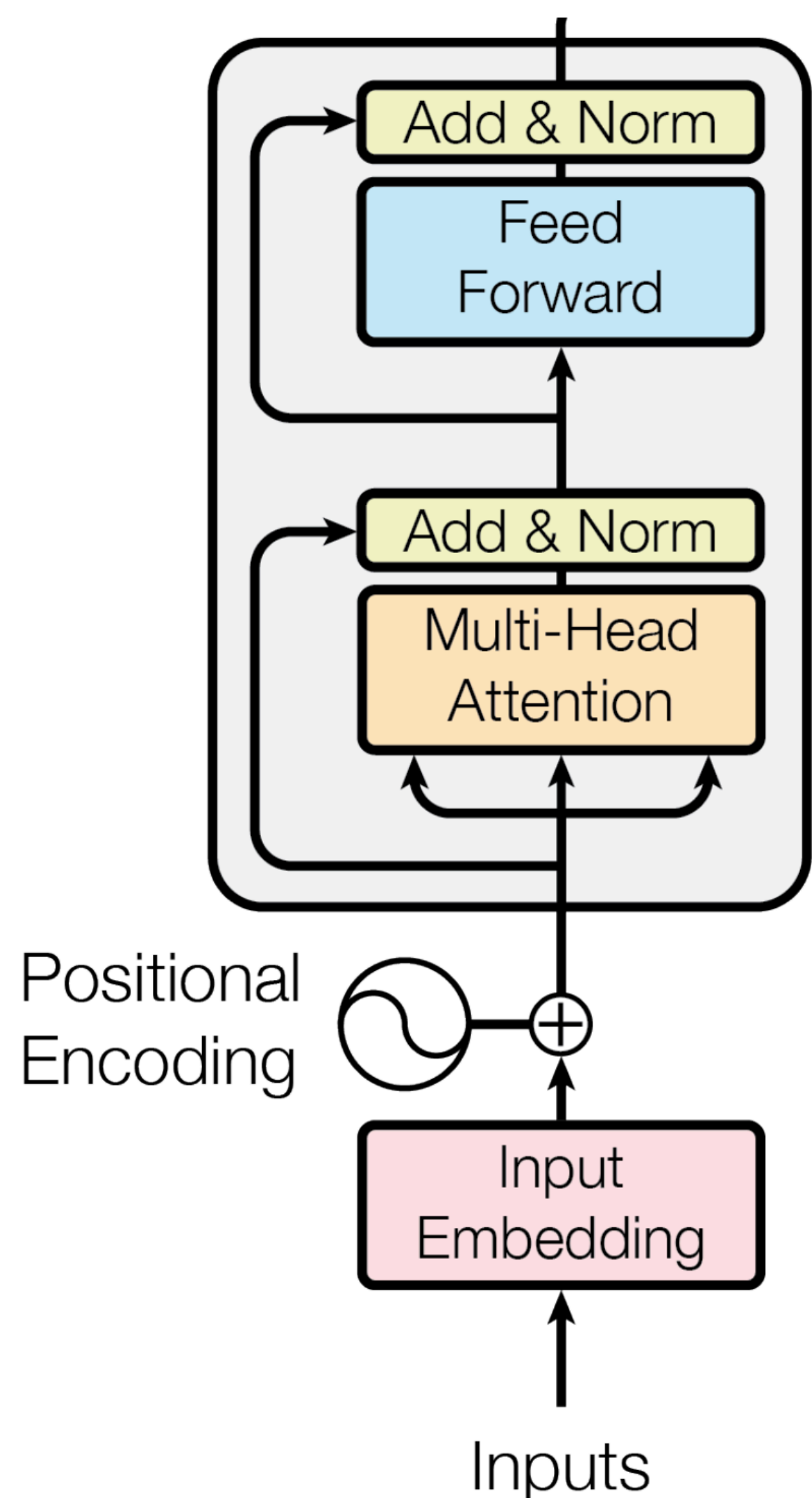

- ▶ Augment word embedding with position embeddings, each dim is a sine/cosine wave of a different frequency. Closer points = higher dot products
- ▶ Works essentially as well as just encoding position as a one-hot vector

Vaswani et al. (2017)

BERT

- ▶ AI2 made ELMo in spring 2018, GPT was released in summer 2018, BERT came out October 2018
- ▶ Three major changes compared to ELMo:
 - ▶ Transformers instead of LSTMs (transformers in GPT as well)
 - ▶ Bidirectional $\Leftarrow \Rightarrow$ Masked LM objective instead of standard LM
 - ▶ Fine-tune instead of freeze at test time

BERT

- ▶ ELMo is a unidirectional model (as is GPT): we can concatenate two unidirectional models, but is this the right thing to do?
- ▶ ELMo reprs look at each direction in isolation; BERT looks at them jointly

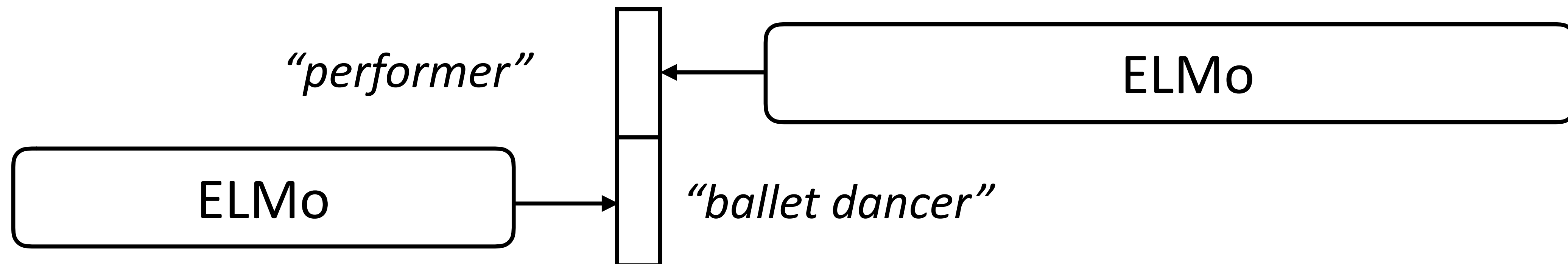

A stunning ballet dancer, Copeland is one of the best performers to see live.

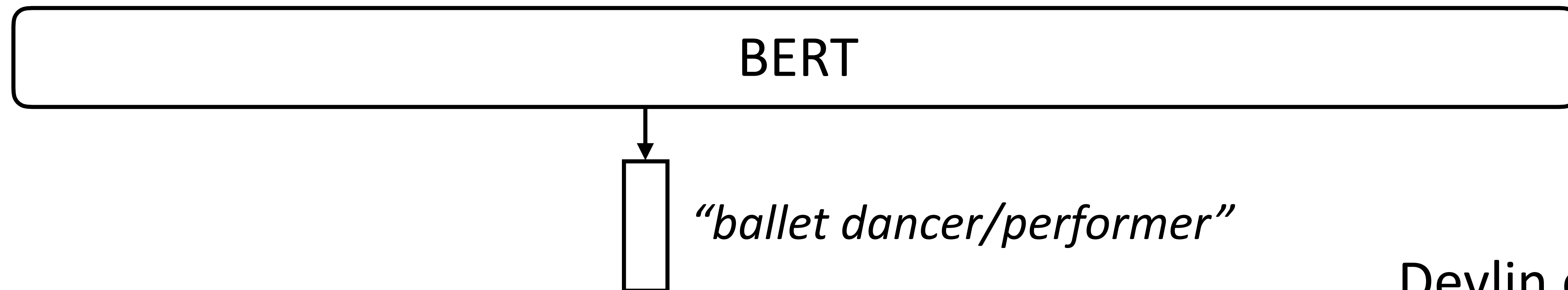

BERT

- ▶ How to learn a “deeply bidirectional” model? What happens if we just replace an LSTM with a transformer?

ELMo (Language Modeling)

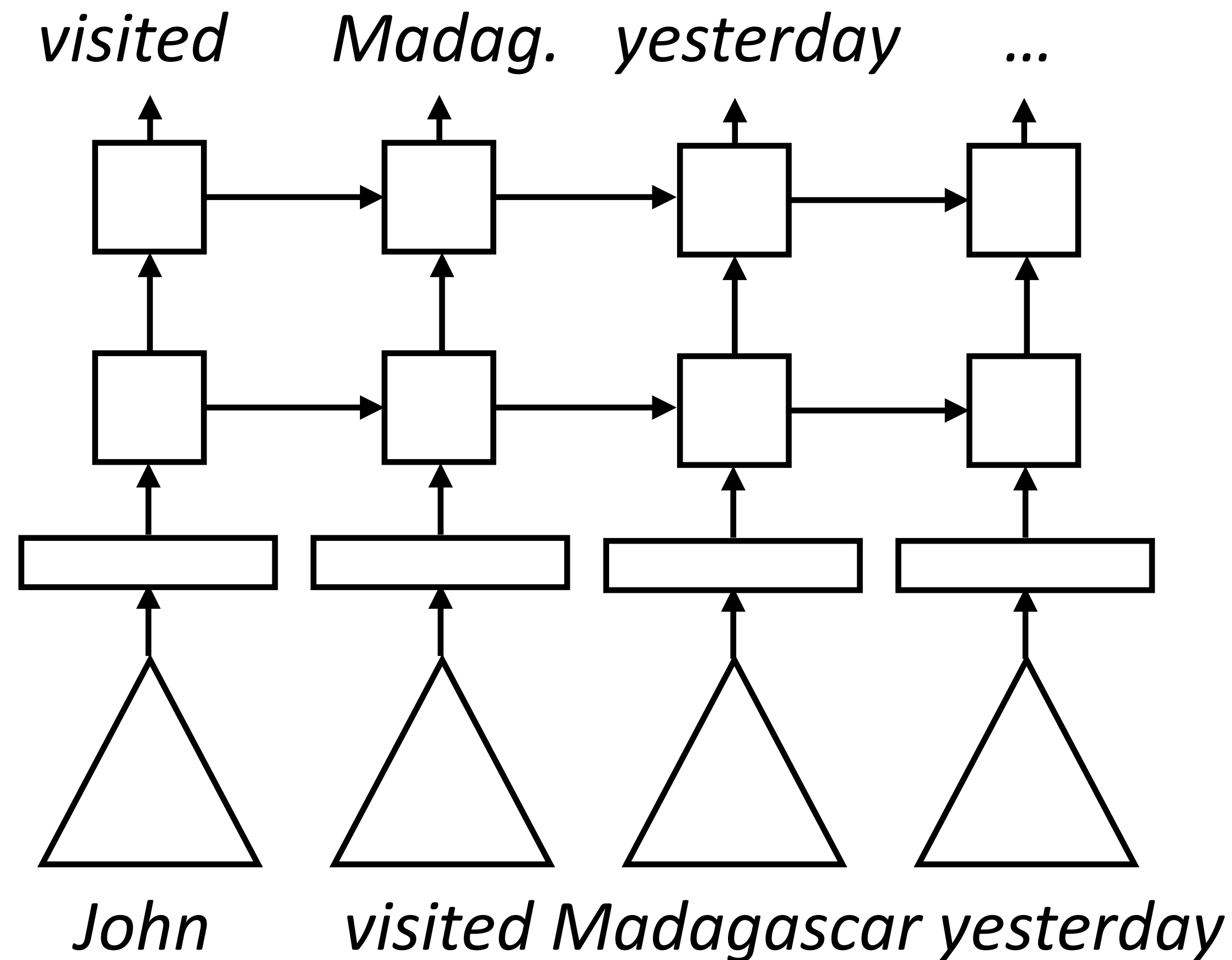

BERT

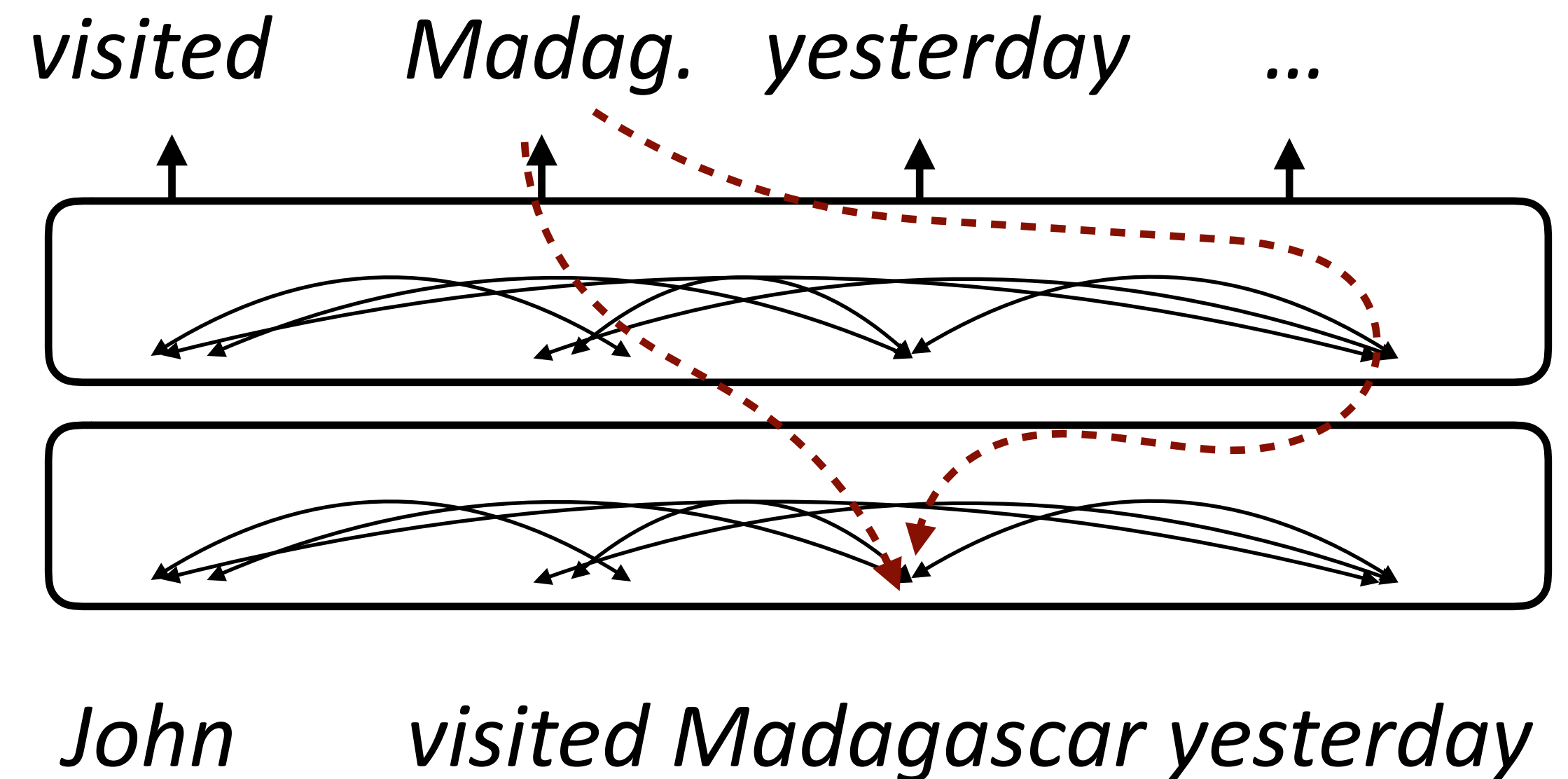

- ▶ Transformer LMs have to be “one-sided” (only attend to previous tokens), not what we want

Masked Language Modeling

- ▶ How to prevent cheating? Next word prediction fundamentally doesn't work for bidirectional models, instead do *masked language modeling*

- ▶ BERT formula: take a chunk of text, predict 15% of the tokens

- ▶ For 80% (of the 15%), replace the input token with [MASK]

- ▶ For 10%, replace w/random

- ▶ For 10%, keep same

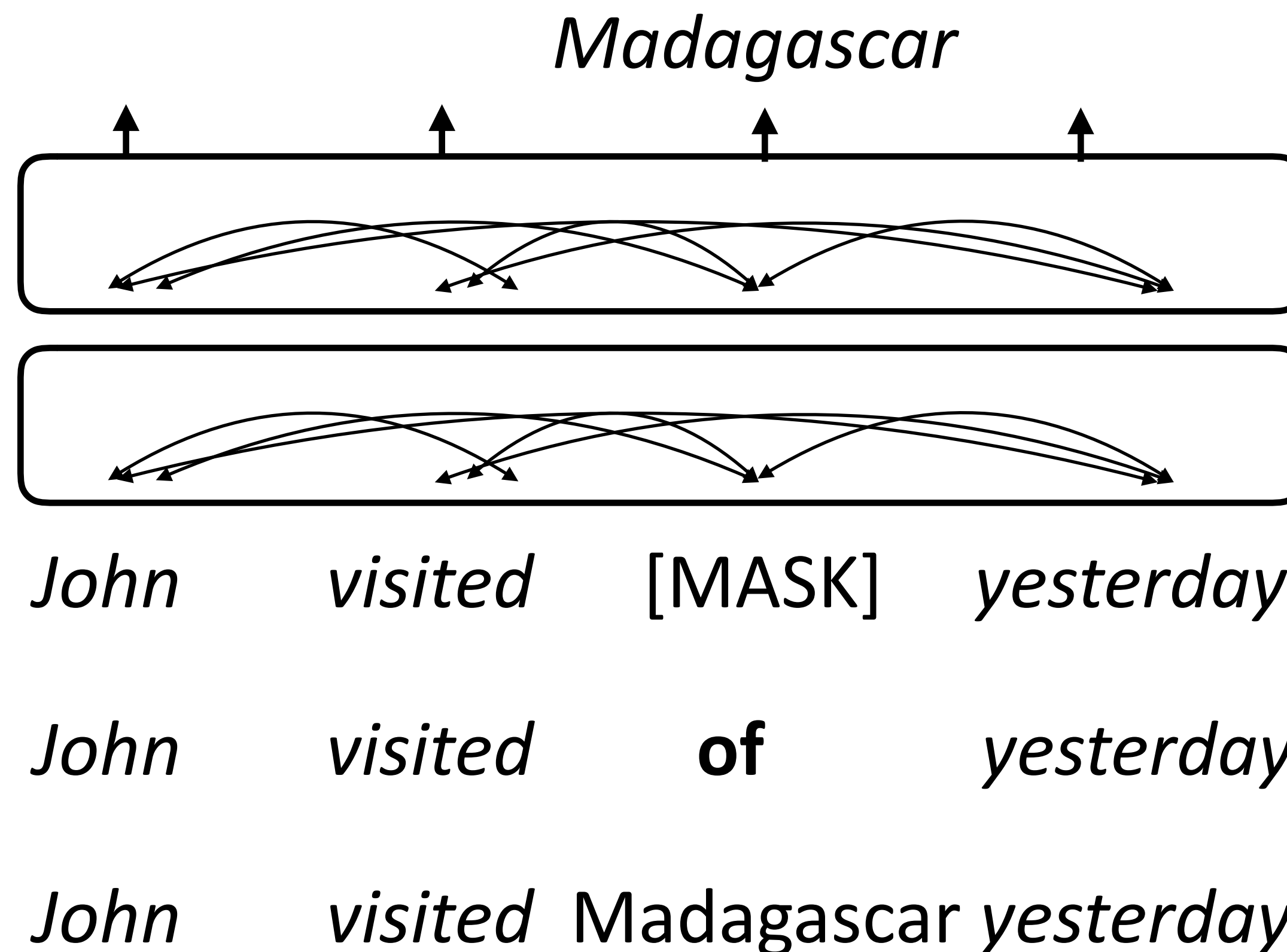

Next “Sentence” Prediction

- ▶ Input: [CLS] Text chunk 1 [SEP] Text chunk 2
- ▶ 50% of the time, take the true next chunk of text, 50% of the time take a random other chunk. Predict whether the next chunk is the “true” next
- ▶ BERT objective: masked LM + next sentence prediction

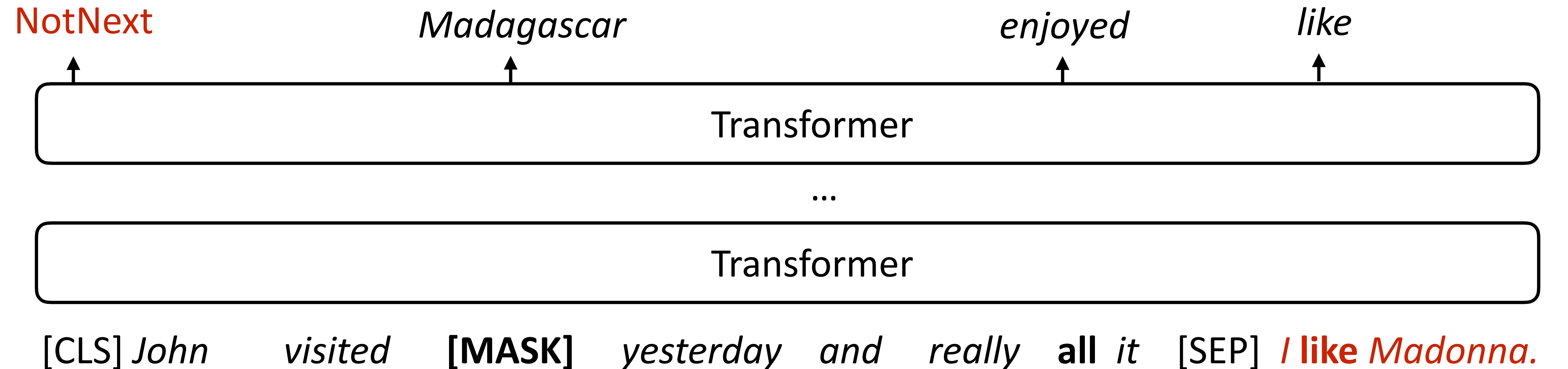

BERT Architecture

- ▶ BERT Base: 12 layers, 768-dim per wordpiece token, 12 heads. Total params = 110M
- ▶ BERT Large: 24 layers, 1024-dim per wordpiece token, 16 heads. Total params = 340M
- ▶ Positional embeddings and segment embeddings, 30k word pieces
- ▶ This is the model that gets **pre-trained** on a large corpus

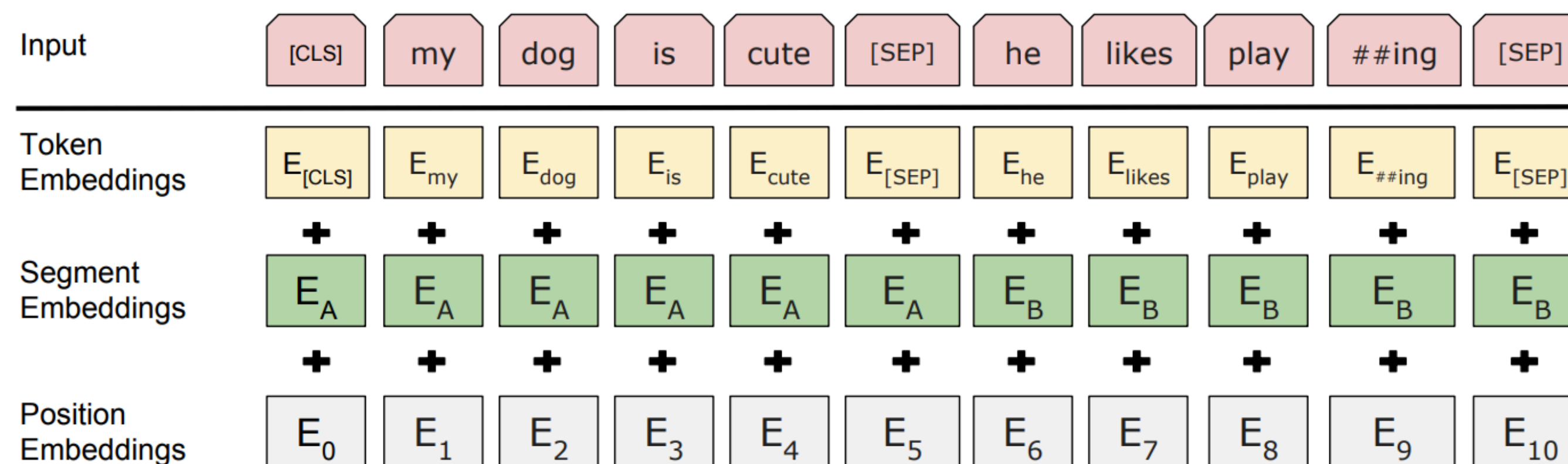
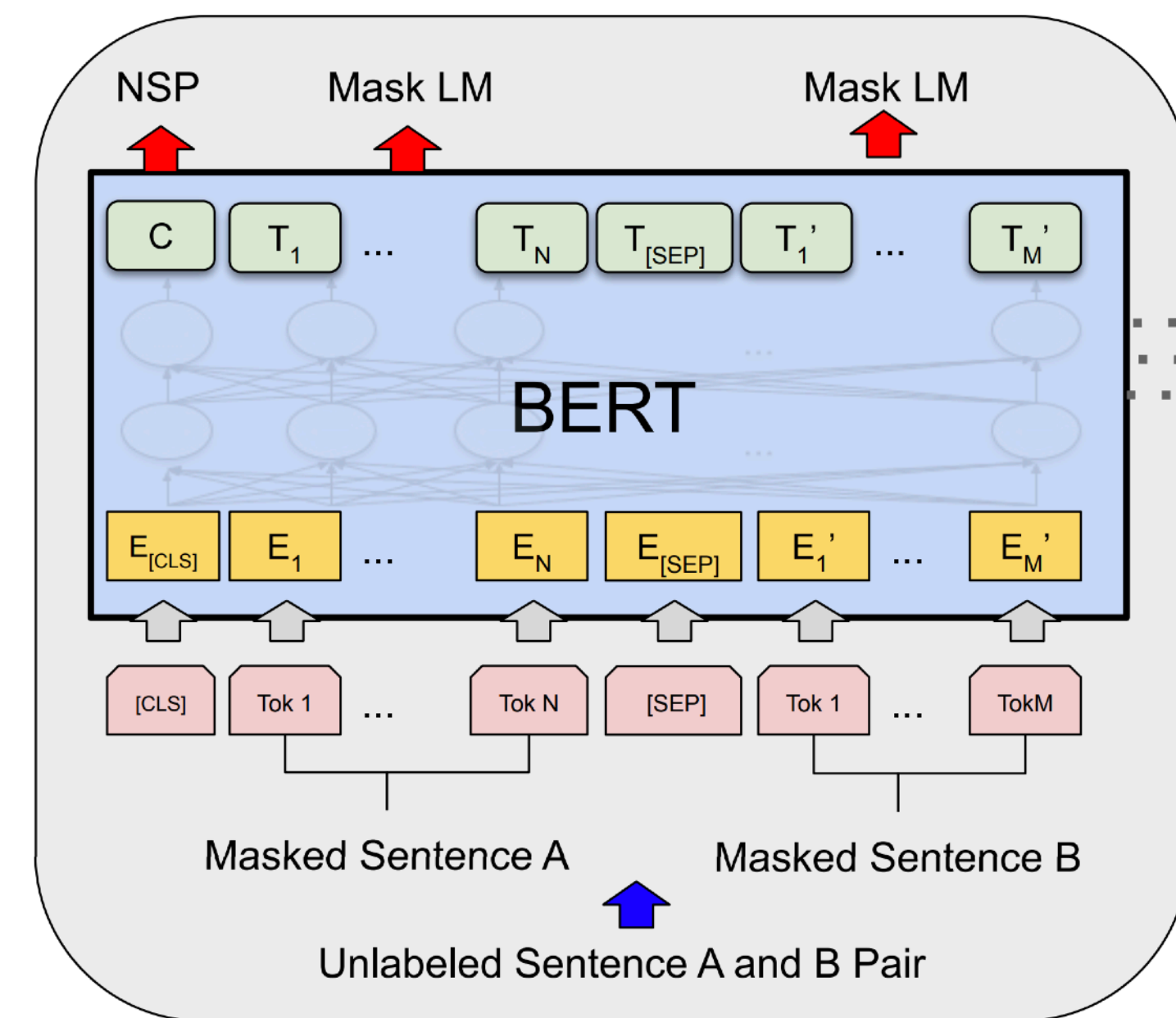

What can BERT do?

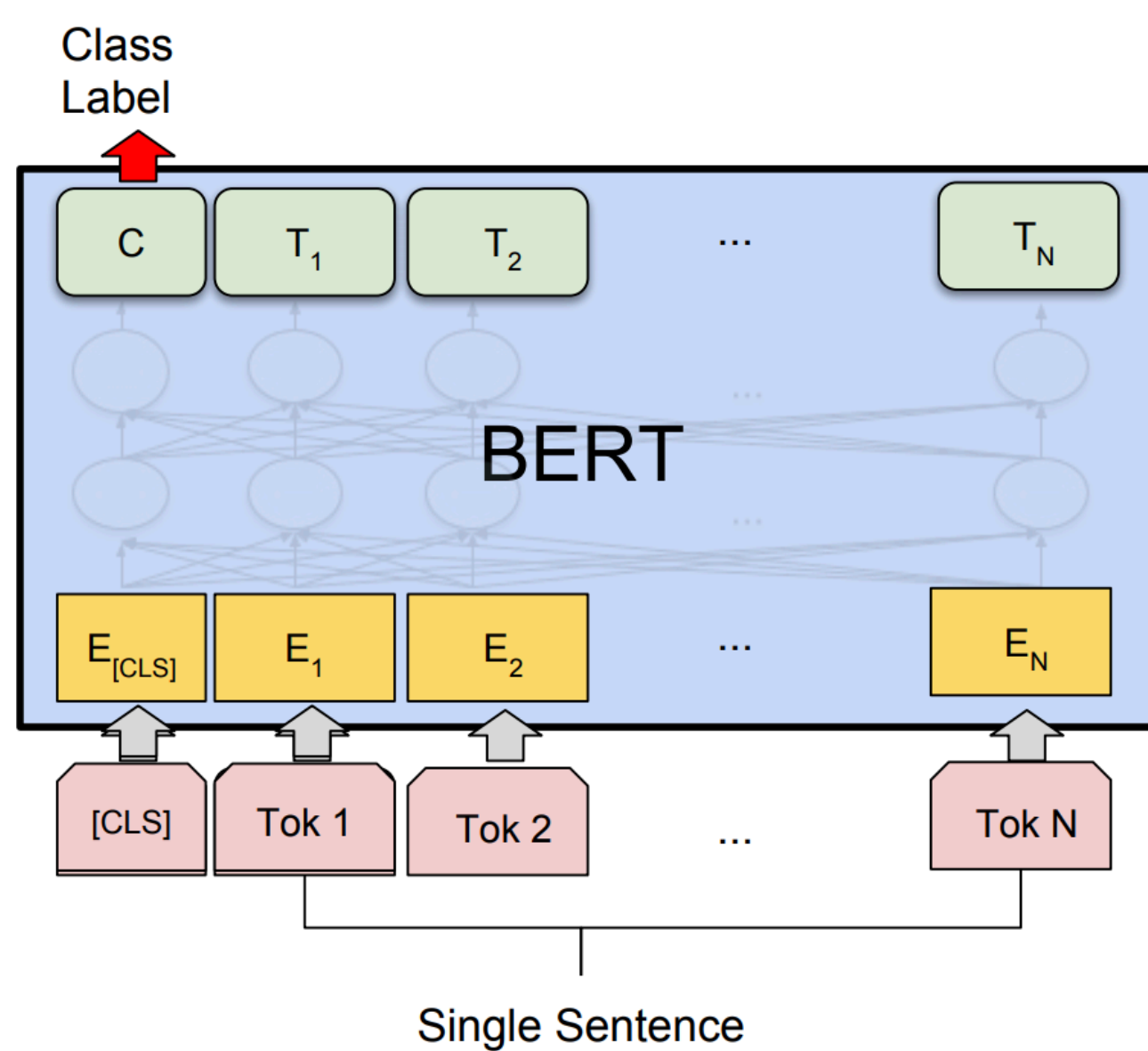

(b) Single Sentence Classification Tasks:
SST-2, CoLA

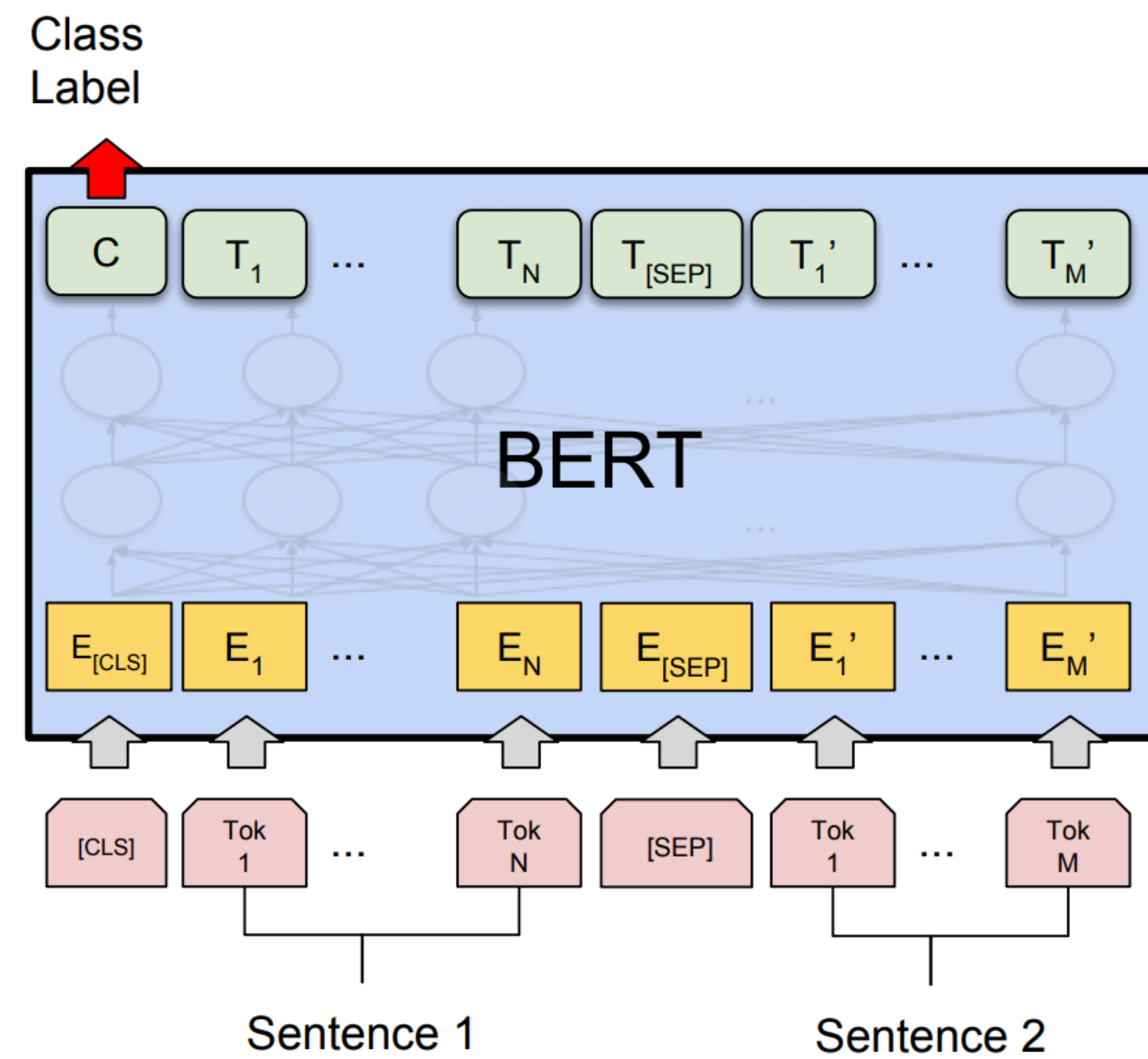

(a) Sentence Pair Classification Tasks:
MNLI, QQP, QNLI, STS-B, MRPC,
RTE, SWAG

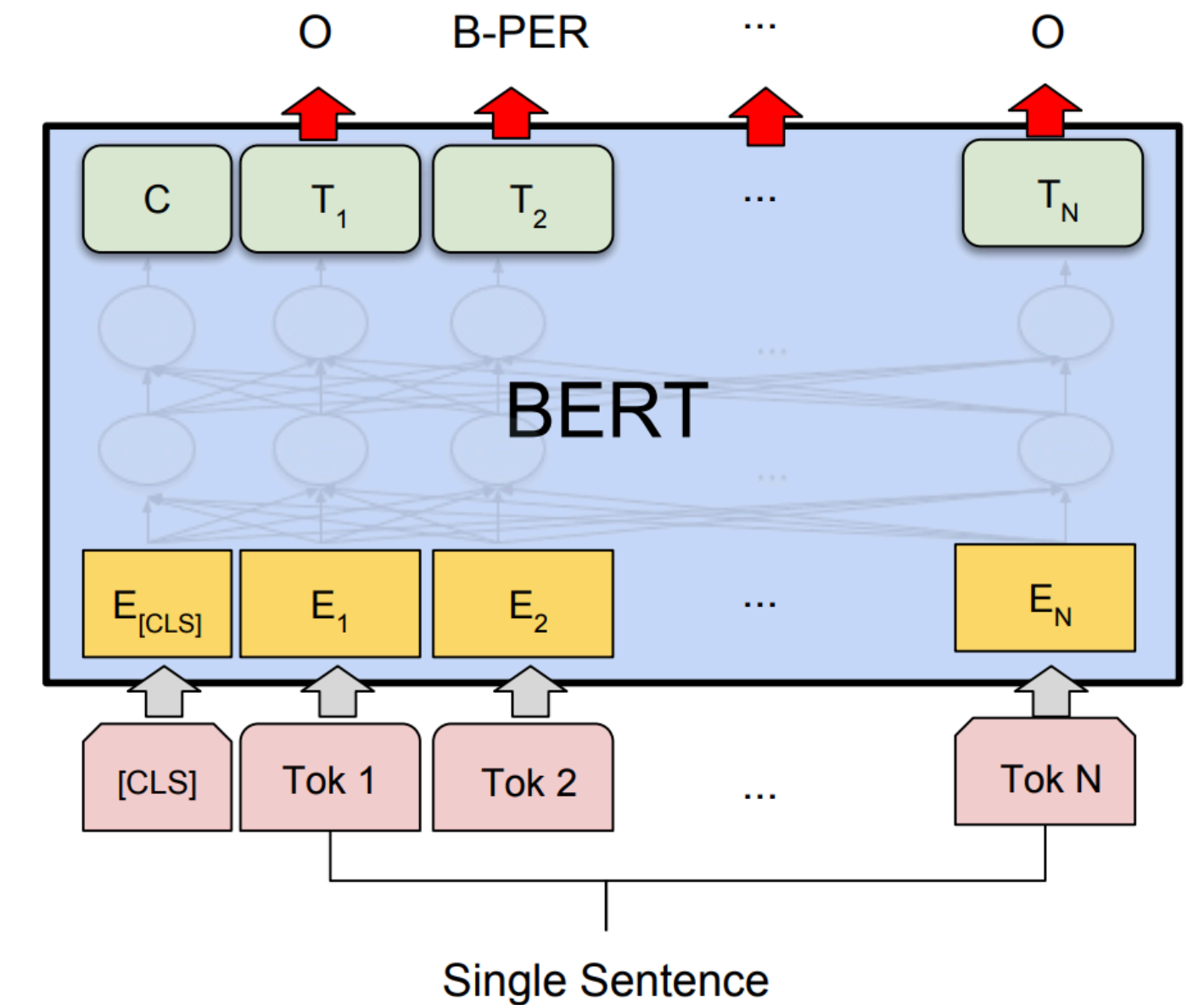

(d) Single Sentence Tagging Tasks:
CoNLL-2003 NER

- ▶ CLS token is used to provide classification decisions
 - ▶ Sentence pair tasks (entailment): feed both sentences into BERT
 - ▶ BERT can also do tagging by predicting tags at each word piece
- Devlin et al. (2019)

What can BERT do?

Entails

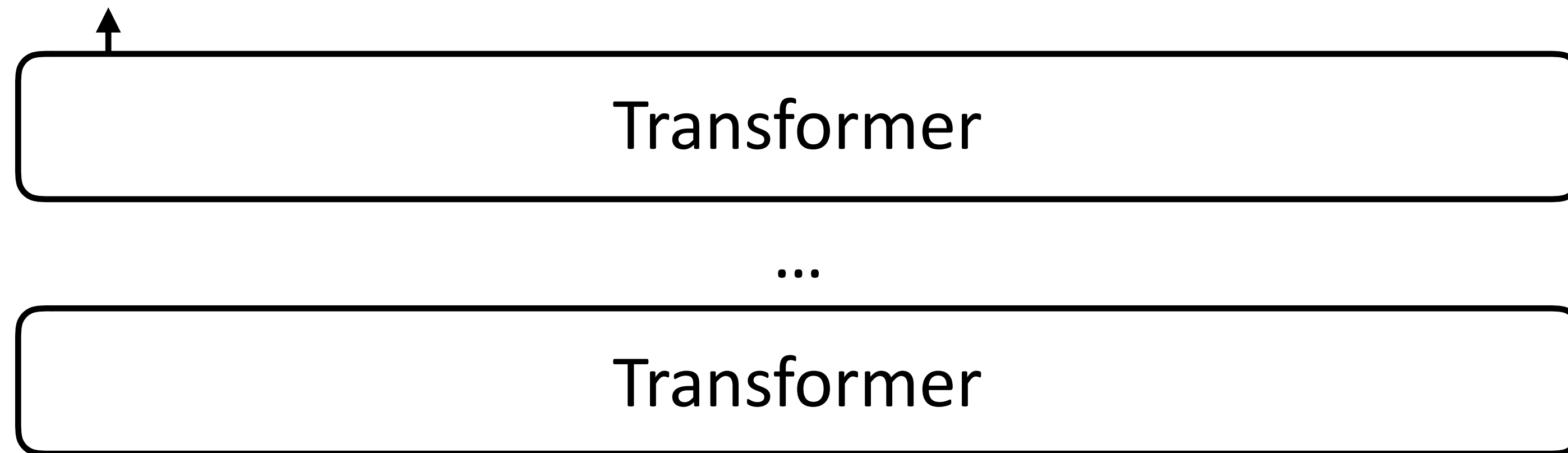

[CLS] A boy plays in the snow [SEP] A boy is outside

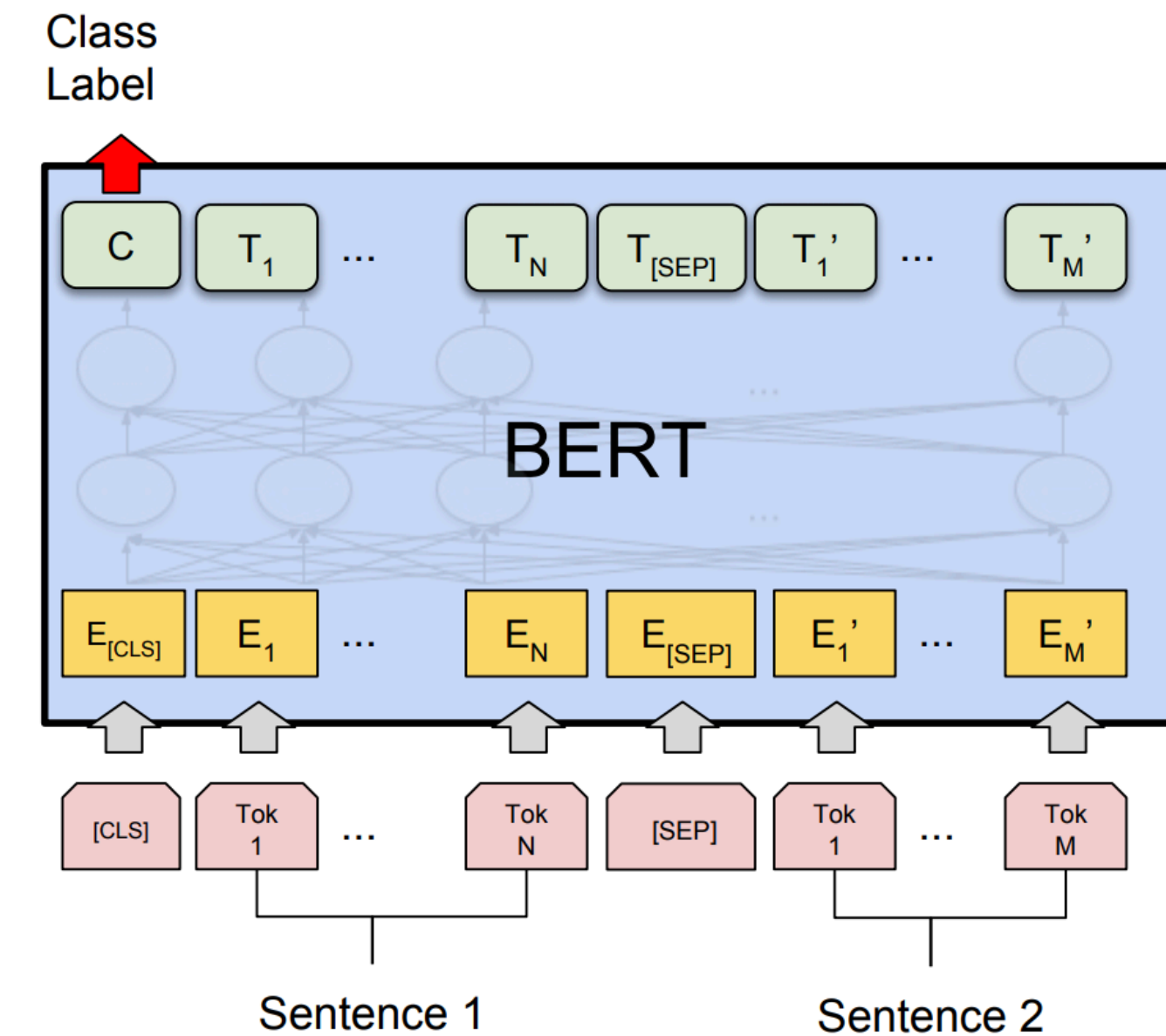

(a) Sentence Pair Classification Tasks: MNLI, QQP, QNLI, STS-B, MRPC, RTE, SWAG

- ▶ How does BERT model this sentence pair stuff?
- ▶ Transformers can capture interactions between the two sentences, even though the NSP objective doesn't really cause this to happen

What can BERT NOT do?

- ▶ BERT **cannot** generate text (at least not in an obvious way)
 - ▶ Not an autoregressive model, can do weird things like stick a [MASK] at the end of a string, fill in the mask, and repeat
- ▶ Masked language models are intended to be used primarily for “analysis” tasks

BERT Results, Extensions

Fine-tuning BERT

- ▶ Fine-tune for 1-3 epochs, batch size 2-32, learning rate $2e-5$ - $5e-5$

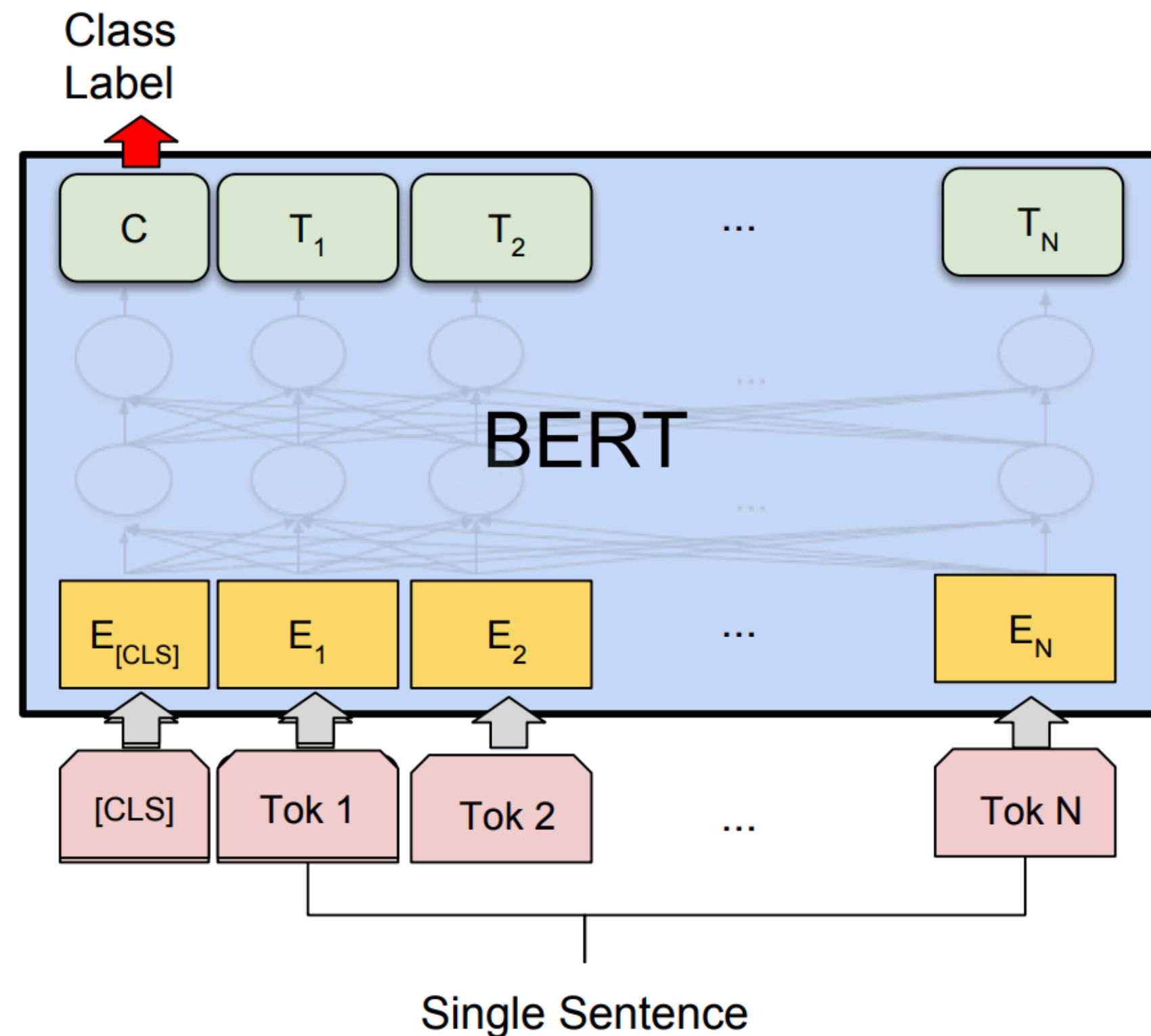

(b) Single Sentence Classification Tasks:
SST-2, CoLA

- ▶ Large changes to weights up here (particularly in last layer to route the right information to [CLS])
- ▶ Smaller changes to weights lower down in the transformer
- ▶ Small LR and short fine-tuning schedule mean weights don't change much
- ▶ More complex "triangular learning rate" schemes exist

Fine-tuning BERT

Pretraining	Adaptation	NER	SA	Nat. lang. inference		Semantic textual similarity		
		CoNLL 2003	SST-2	MNLI	SICK-E	SICK-R	MRPC	STS-B
Skip-thoughts	❄️	-	81.8	62.9	-	86.6	75.8	71.8
ELMo	❄️	91.7	91.8	79.6	86.3	86.1	76.0	75.9
	🔥	91.9	91.2	76.4	83.3	83.3	74.7	75.5
	$\Delta = \text{🔥} - \text{❄️}$	0.2	-0.6	-3.2	-3.3	-2.8	-1.3	-0.4
BERT-base	❄️	92.2	93.0	84.6	84.8	86.4	78.1	82.9
	🔥	92.4	93.5	84.6	85.8	88.7	84.8	87.1
	$\Delta = \text{🔥} - \text{❄️}$	0.2	0.5	0.0	1.0	2.3	6.7	4.2

- ▶ BERT is typically better if the whole network is fine-tuned, unlike ELMo

Evaluation: GLUE

Corpus	Train	Test	Task	Metrics	Domain
Single-Sentence Tasks					
CoLA	8.5k	1k	acceptability	Matthews corr.	misc.
SST-2	67k	1.8k	sentiment	acc.	movie reviews
Similarity and Paraphrase Tasks					
MRPC	3.7k	1.7k	paraphrase	acc./F1	news
STS-B	7k	1.4k	sentence similarity	Pearson/Spearman corr.	misc.
QQP	364k	391k	paraphrase	acc./F1	social QA questions
Inference Tasks					
MNLI	393k	20k	NLI	matched acc./mismatched acc.	misc.
QNLI	105k	5.4k	QA/NLI	acc.	Wikipedia
RTE	2.5k	3k	NLI	acc.	news, Wikipedia
WNLI	634	146	coreference/NLI	acc.	fiction books

Results

System	MNLI-(m/mm) 392k	QQP 363k	QNLI 108k	SST-2 67k	CoLA 8.5k	STS-B 5.7k	MRPC 3.5k	RTE 2.5k	Average
Pre-OpenAI SOTA	80.6/80.1	66.1	82.3	93.2	35.0	81.0	86.0	61.7	74.0
BiLSTM+ELMo+Attn	76.4/76.1	64.8	79.9	90.4	36.0	73.3	84.9	56.8	71.0
OpenAI GPT	82.1/81.4	70.3	88.1	91.3	45.4	80.0	82.3	56.0	75.2
BERT _{BASE}	84.6/83.4	71.2	90.1	93.5	52.1	85.8	88.9	66.4	79.6
BERT _{LARGE}	86.7/85.9	72.1	91.1	94.9	60.5	86.5	89.3	70.1	81.9

- ▶ Huge improvements over prior work (even compared to ELMo)
- ▶ Effective at “sentence pair” tasks: textual entailment (does sentence A imply sentence B), paraphrase detection

Devlin et al. (2018)

RoBERTa

- ▶ “Robustly optimized BERT”
- ▶ 160GB of data instead of 16 GB
- ▶ Dynamic masking: standard BERT uses the same MASK scheme for every epoch, RoBERTa recomputes them
- ▶ New training + more data = better performance

Model	data	bsz	steps	SQuAD (v1.1/2.0)	MNLI-m	SST-2
RoBERTa						
with BOOKS + WIKI	16GB	8K	100K	93.6/87.3	89.0	95.3
+ additional data (§3.2)	160GB	8K	100K	94.0/87.7	89.3	95.6
+ pretrain longer	160GB	8K	300K	94.4/88.7	90.0	96.1
+ pretrain even longer	160GB	8K	500K	94.6/89.4	90.2	96.4
BERT _{LARGE}						
with BOOKS + WIKI	13GB	256	1M	90.9/81.8	86.6	93.7

ALBERT

- ▶ Factorized embedding matrix to save parameters, model context-independent words with fewer parameters

Ordinarily $|V| \times H$ — $|V|$ is 30k-90k, H is >1000

Factor into two matrices with a low-rank approximation

Now: $|V| \times E$ and $E \times H$ — E is 128 in their implementation

- ▶ Additional cross-layer parameter sharing

ELECTRA

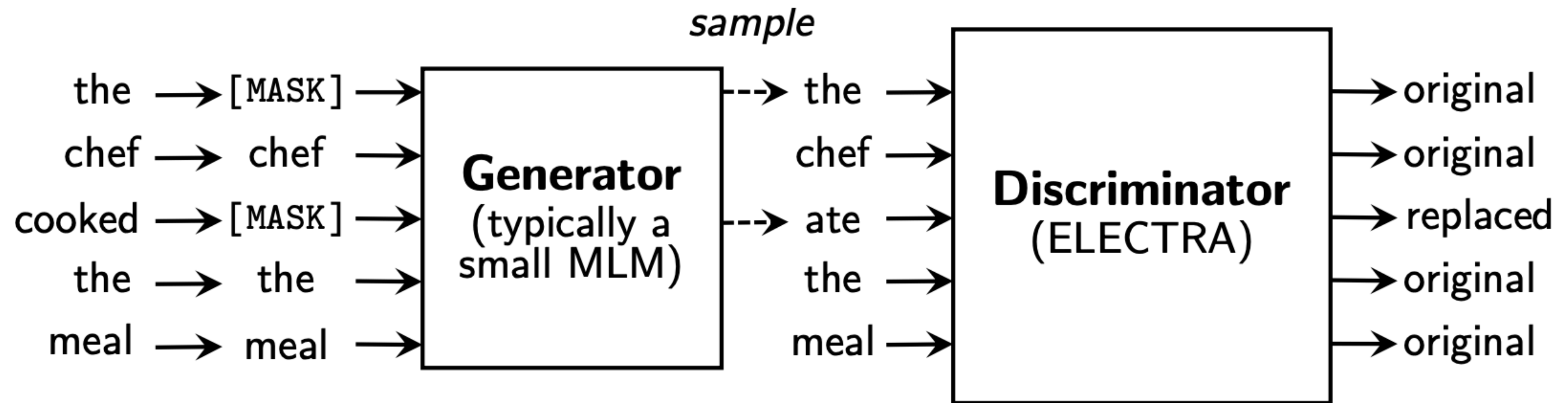

- ▶ No need to necessarily have a generative model (predicting words)
- ▶ This objective is more computationally efficient (trains faster) than the standard BERT objective

BERT/MLMs

- ▶ There are lots of ways to train these models!
- ▶ Key factors:
 - ▶ Big enough model
 - ▶ Big enough data
 - ▶ Well-designed “self-supervised” objective (something like language modeling). Needs to be a hard enough problem!

Analysis/Visualization of BERT

BERTology

- (1) How can we probe syntactic + semantic knowledge of BERT? What does BERT “know” in its representations?
- (2) What can we learn from looking at attention heads?
- (3) What can we learn about training BERT (more efficiently, etc.)?

BERTology: Probing

(1) In general: set up some “probing” task to try to determine syntactic features from BERT’s hidden states

E.g.: Words with syntactic relations have a higher impact on one another during MLM prediction

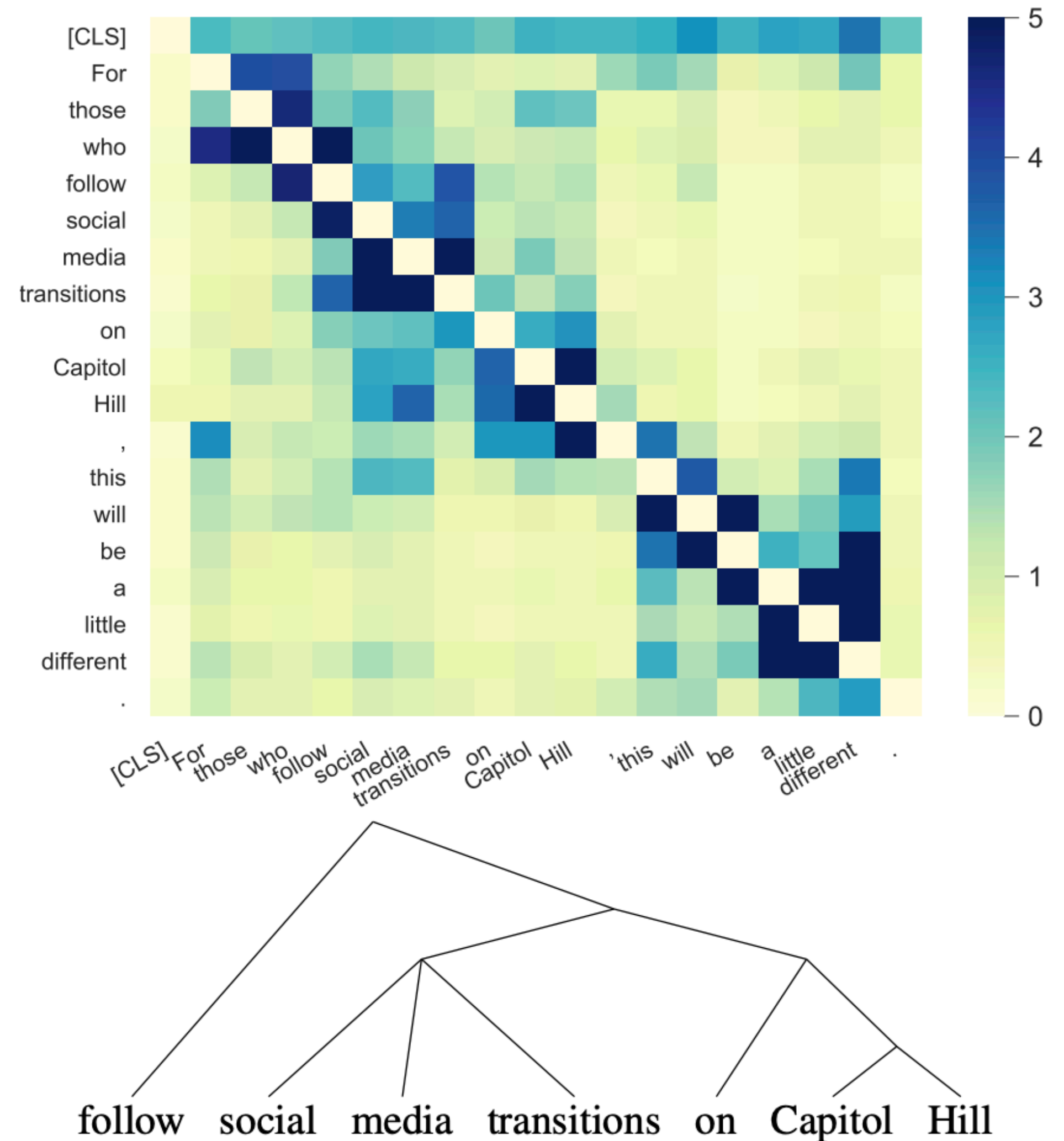

Rogers et al. (2020)

BERTology

(2) What's going inside attention heads?

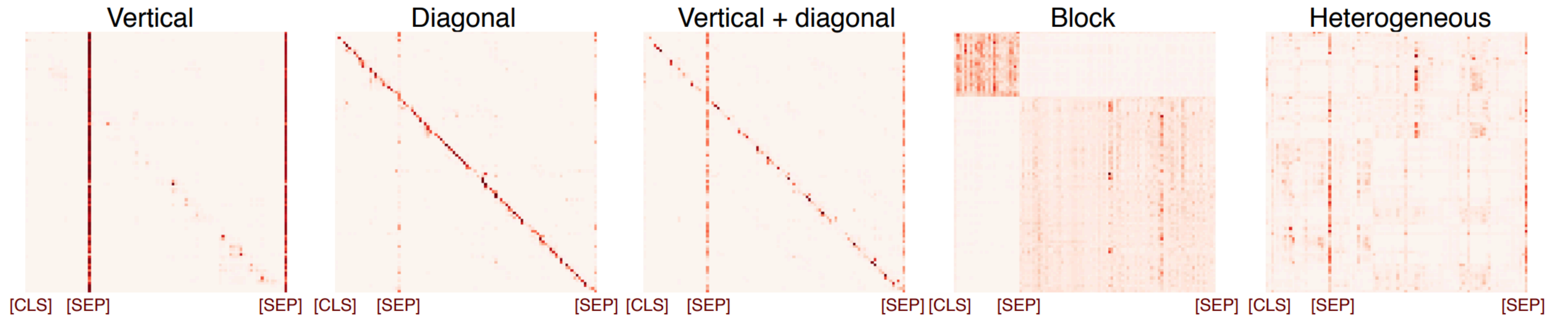

What does BERT learn?

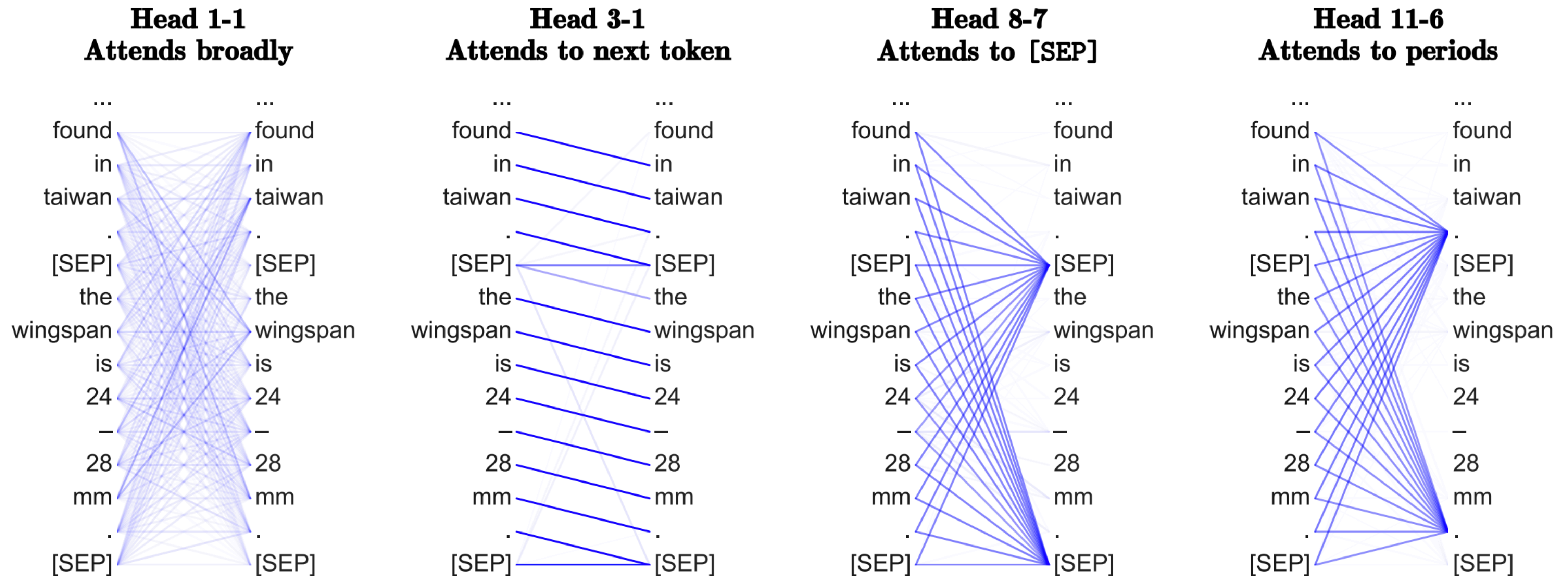

- ▶ Heads on transformers learn interesting and diverse things: content heads (attend based on content), positional heads (based on position), etc.

What does BERT learn?

Head 8-10

- **Direct objects** attend to their verbs
- 86.8% accuracy at the dobj relation

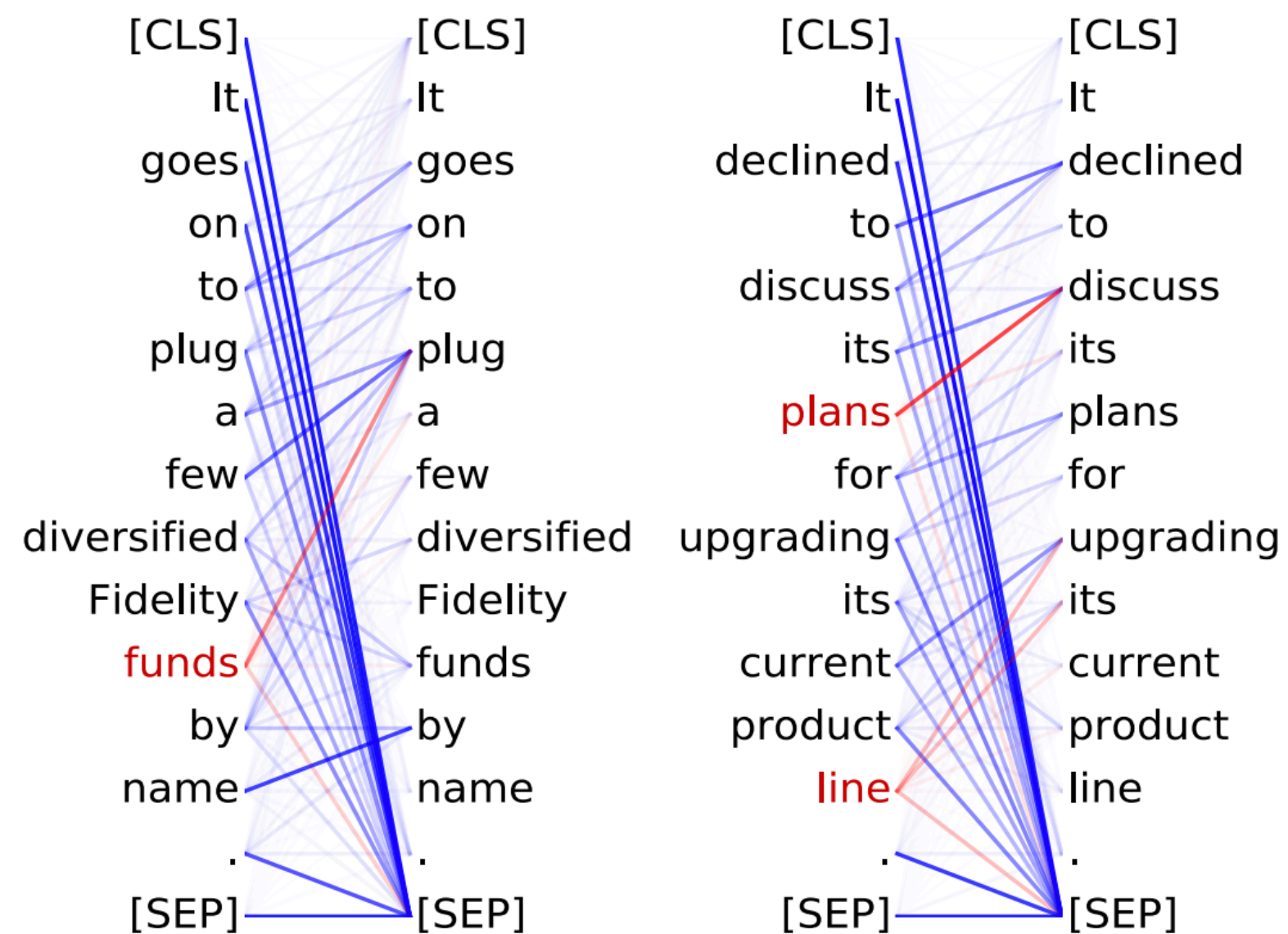

Head 8-11

- **Noun modifiers** (e.g., determiners) attend to their noun
- 94.3% accuracy at the det relation

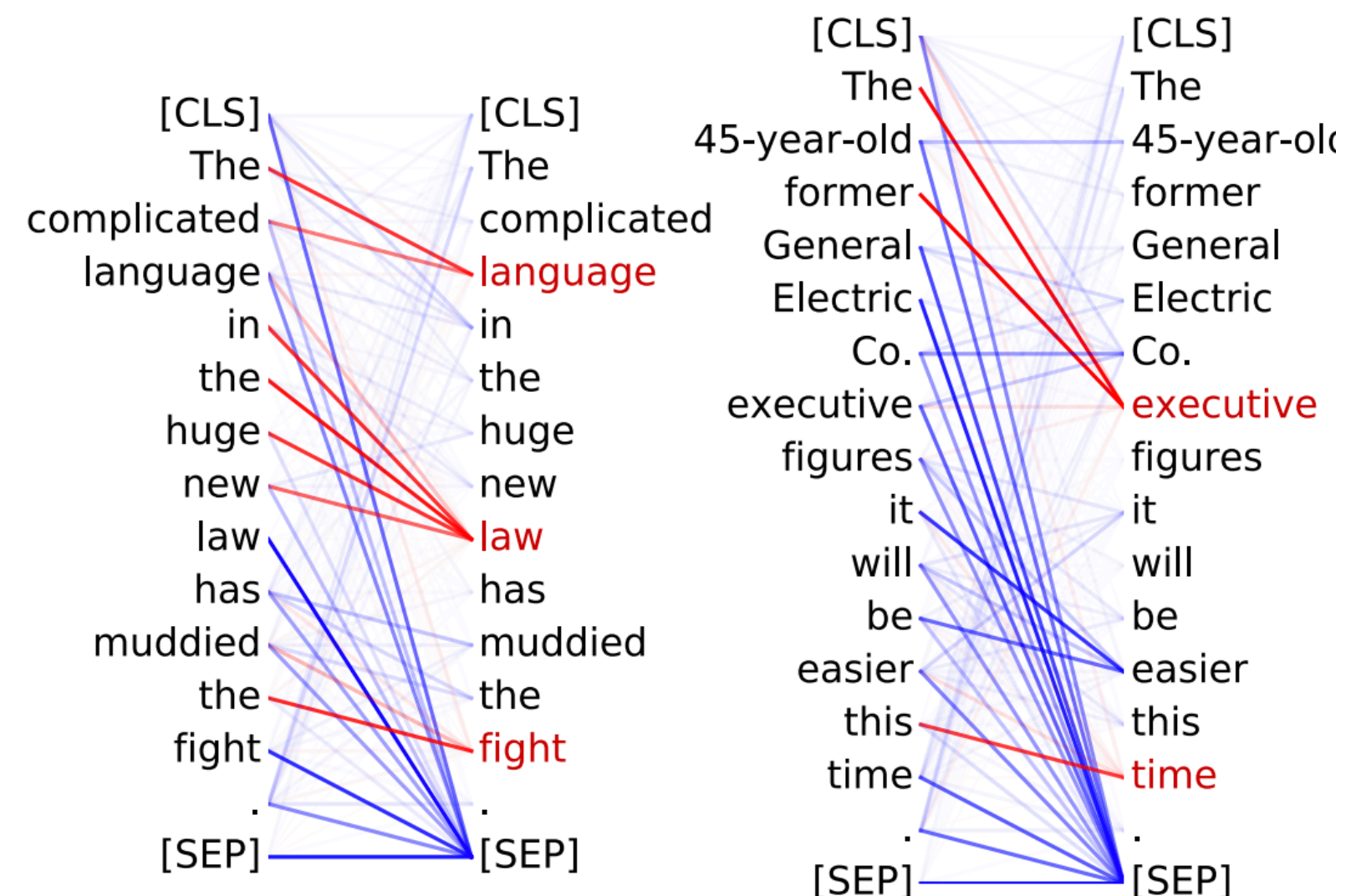

Head 5-4

- **Coreferent** mentions attend to their antecedents
- 65.1% accuracy at linking the head of a coreferent mention to the head of an antecedent

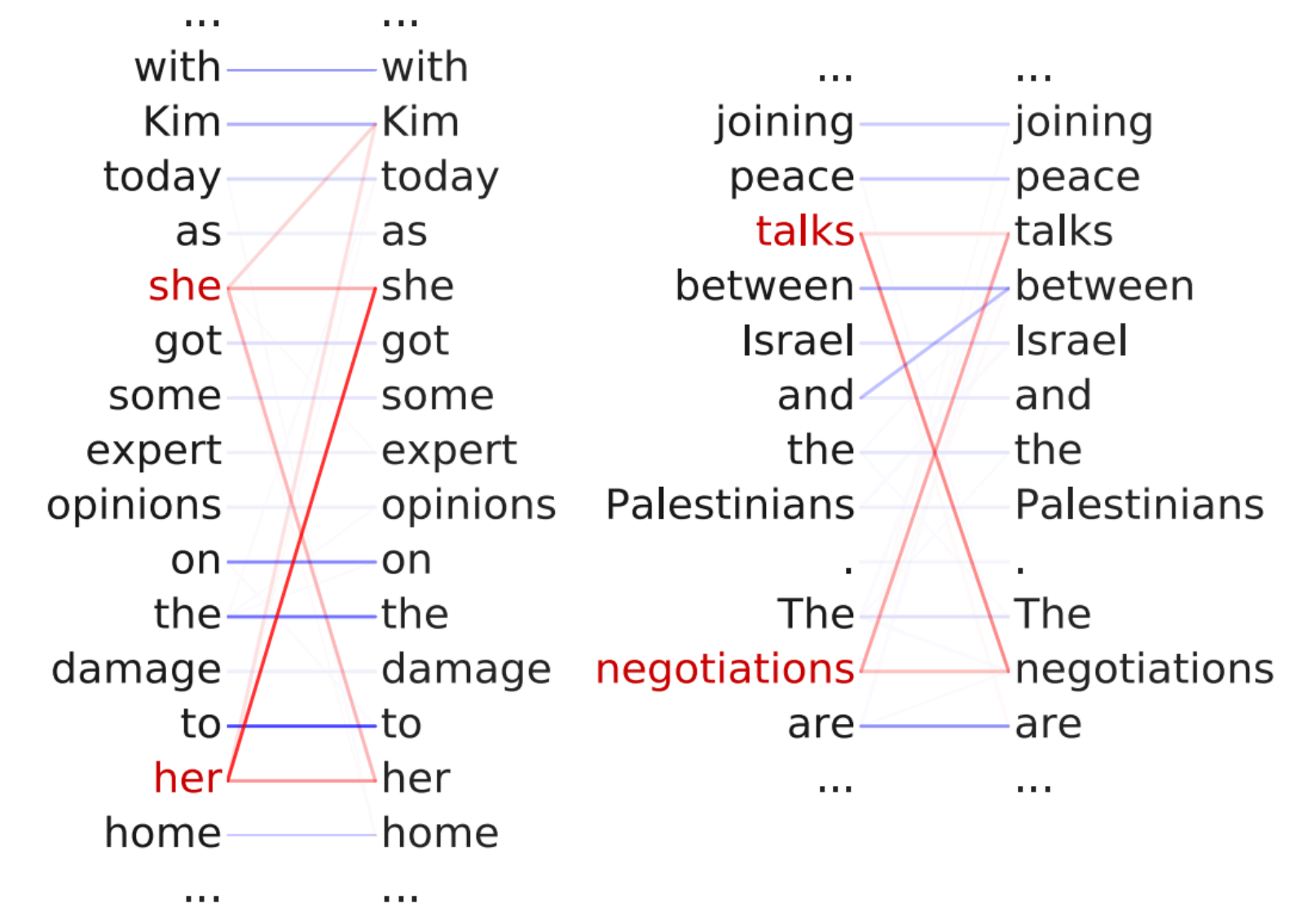

- ▶ Still way worse than what supervised systems can do, but interesting that this is learned organically

Compressing BERT

- ▶ Remove 60+% of BERT's heads post-training with minimal drop in performance
- ▶ DistilBERT (Sanh et al., 2019): nearly as good with half the parameters of BERT (via knowledge distillation)

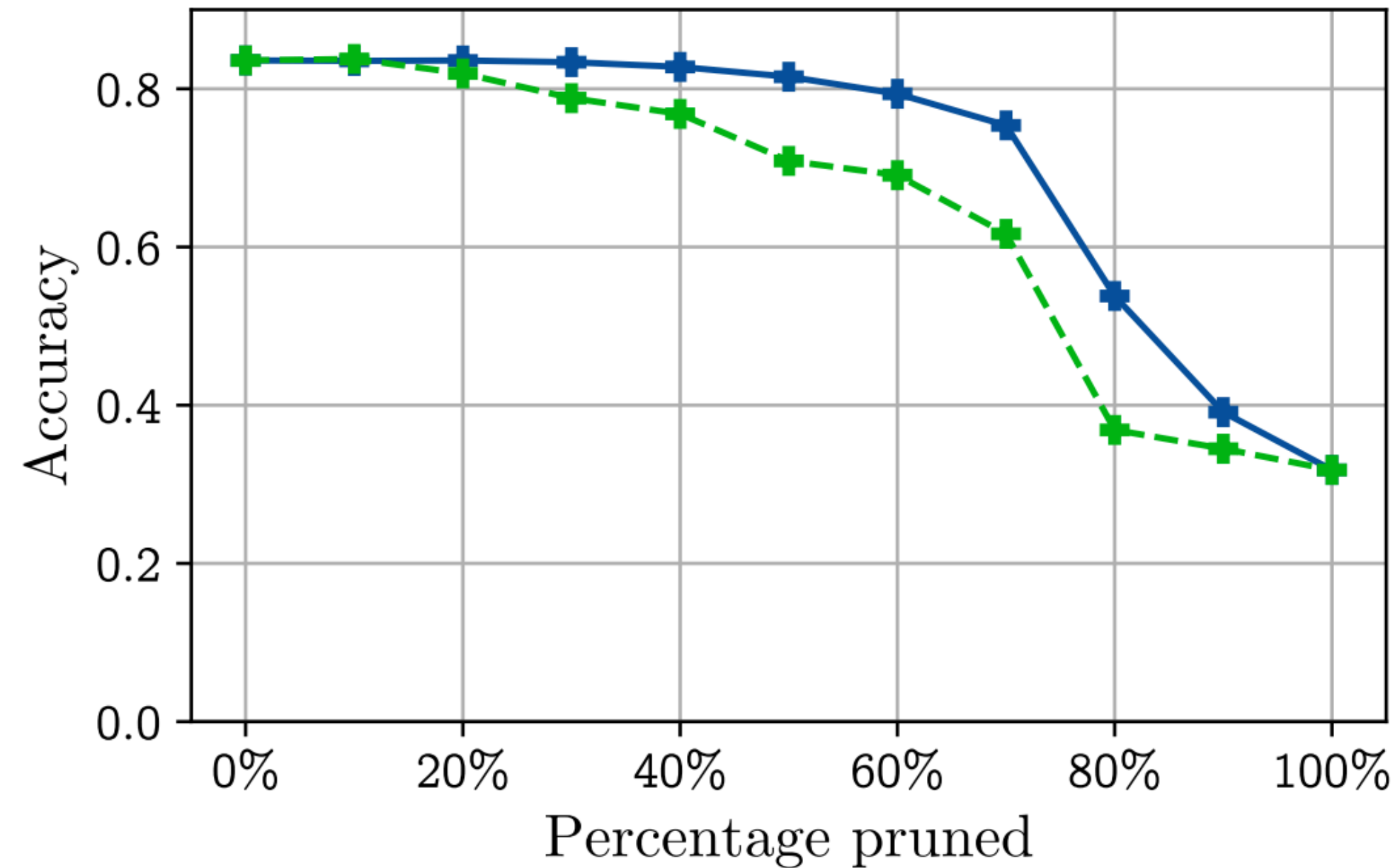

(b) Evolution of accuracy on the MultiNLI-matched validation set when heads are pruned from BERT according to I_h (solid blue) and accuracy difference (dashed green).

GPT/GPT2

OpenAI GPT/GPT2

- ▶ “ELMo with transformers” (works better than ELMo)
- ▶ Train a single unidirectional transformer LM on long contexts

- ▶ GPT2: trained on 40GB of text collected from upvoted links from reddit
- ▶ 1.5B parameters — by far the largest of these models trained as of March 2019

Parameters	Layers	d_{model}
117M	12	768
345M	24	1024
762M	36	1280
1542M	48	1600

- ▶ Because it's a language model, we can **generate** from it

OpenAI GPT2

SYSTEM PROMPT
(HUMAN-WRITTEN)

Miley Cyrus was caught shoplifting from Abercrombie and Fitch on Hollywood Boulevard today.

MODEL COMPLETION
(MACHINE-WRITTEN,
SECOND TRY)

The 19-year-old singer was caught on camera being escorted out of the store by security guards.

The singer was wearing a black hoodie with the label 'Blurred Lines' on the front and 'Fashion Police' on the back.

Scroll down for video

Shoplifting: Miley Cyrus was caught shoplifting from Abercrombie and Fitch on Hollywood Boulevard today (pictured)

The singer was wearing a black hoodie with the label 'Blurred Lines' on the front and 'Fashion Police' on the back

The singer was also wearing a pair of black-rimmed glasses, a black jacket, black jeans and black sandals.

She was carrying a pair of black and white striped gloves and a small black bag.

slide credit:
OpenAI

Open Questions

- 1) How novel is the stuff being generated? (Is it just doing nearest neighbors on a large corpus?)
- 2) How do we understand and distill what is learned in this model?
- 3) How do we harness these priors for conditional generation tasks (summarization, generate a report of a basketball game, etc.)
- 4) Is this technology dangerous?

Grover

- ▶ Sample from a large language model conditioned on a domain, date, authors, and headline
- ▶ Humans rank Grover-generated propaganda as more realistic than real “fake news”
- ▶ Fine-tuned Grover can detect Grover propaganda easily — authors argue for releasing it for this reason
- ▶ NOTE: Not a GAN, discriminator trained separately from the generator

		Unpaired Accuracy			Paired Accuracy				
		Generator size			Generator size				
		1.5B	355M	124M		1.5B	355M	124M	
Chance		50.0				50.0			
Discriminator size	1.5B	GROVER-Mega	92.0	98.5	99.8		97.4	100.0	100.0
		GROVER-Large	80.8	91.2	98.4		89.0	96.9	100.0
	355M	BERT-Large	73.1	75.9	97.5		84.1	91.5	99.9
		GPT2	70.1	78.0	90.3		78.8	87.0	96.8
		GROVER-Base	70.1	80.0	89.2		77.5	88.2	95.7
	124M	BERT-Base	67.2	76.6	84.1		80.0	89.5	96.2
		GPT2	66.2	71.9	83.5		72.5	79.6	89.6
	11M	FastText	63.8	65.6	69.7		65.9	69.0	74.4

Pre-Training Cost (with Google/AWS)

- ▶ BERT: Base \$500, Large \$7000
- ▶ Grover-MEGA: \$25,000
- ▶ XLNet (BERT variant): \$30,000 — \$60,000 (unclear)
- ▶ This is for a single pre-training run...developing new pre-training techniques may require many runs
- ▶ *Fine-tuning* these models can typically be done with a single GPU (but may take 1-3 days for medium-sized datasets)

Takeaways

- ▶ BERT-based systems are state-of-the-art for nearly every major text analysis task
- ▶ Transformers + lots of data + self-supervision seems to do very well
- ▶ Lots of work studying and analyzing these, but few “deep” conclusions have emerged
- ▶ Next time: modifications of these (BART/T5, GPT-3, etc.)